

PLANIMETRIA OPERE IN PROGETTO scala 1:500

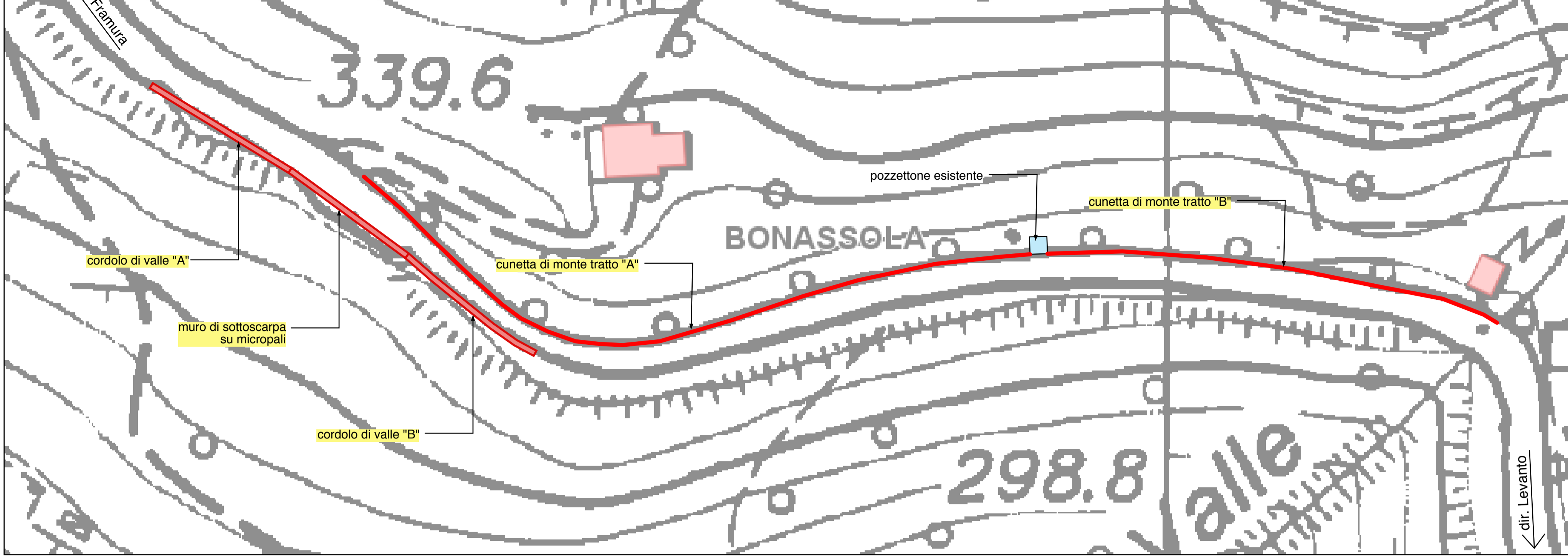

STRALCIO C.T.R. scala 1:5.000

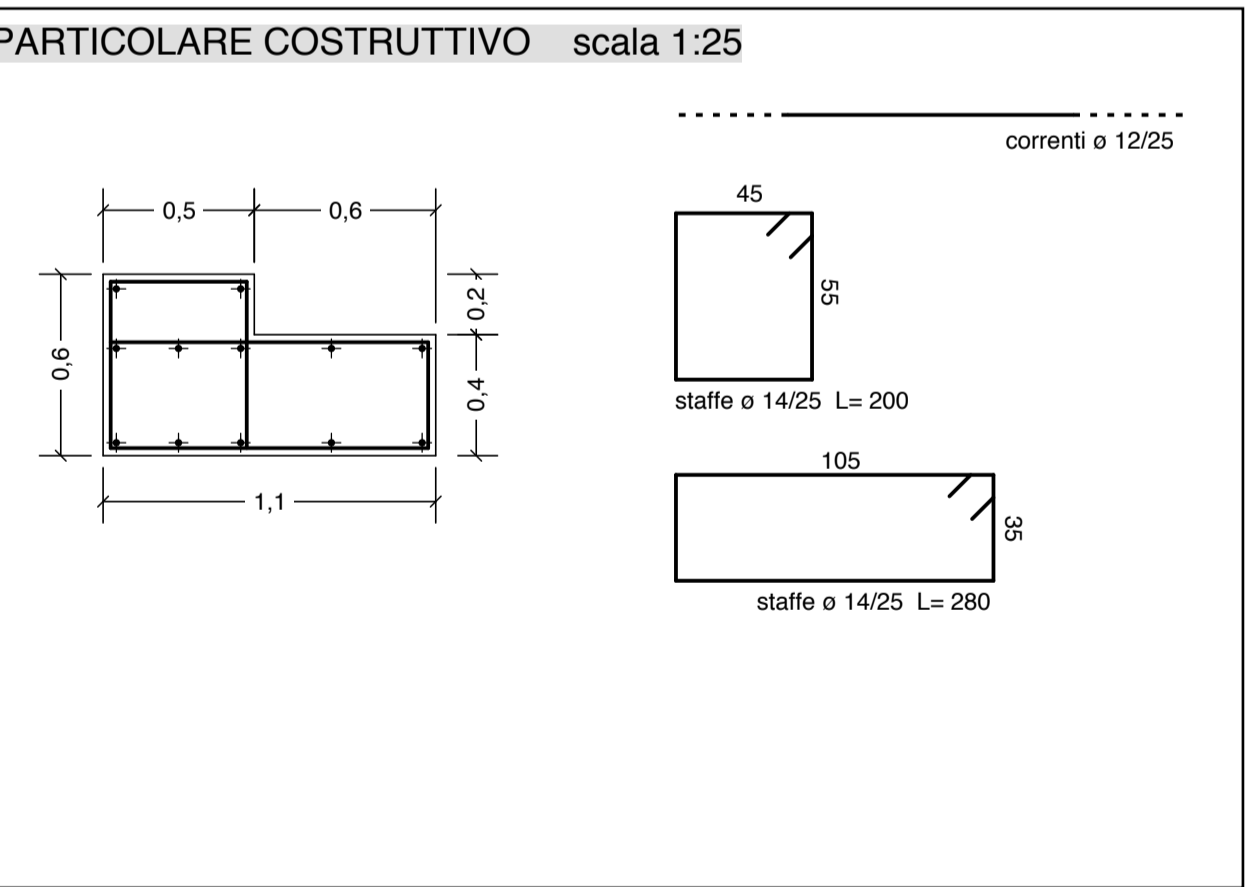
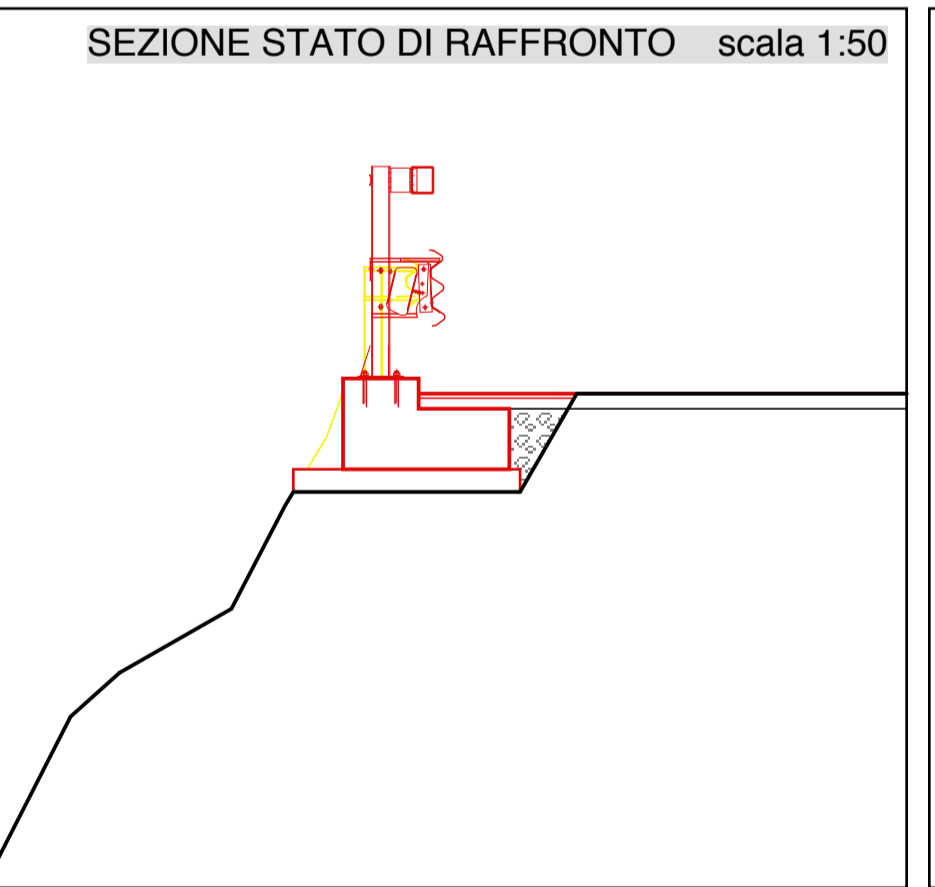
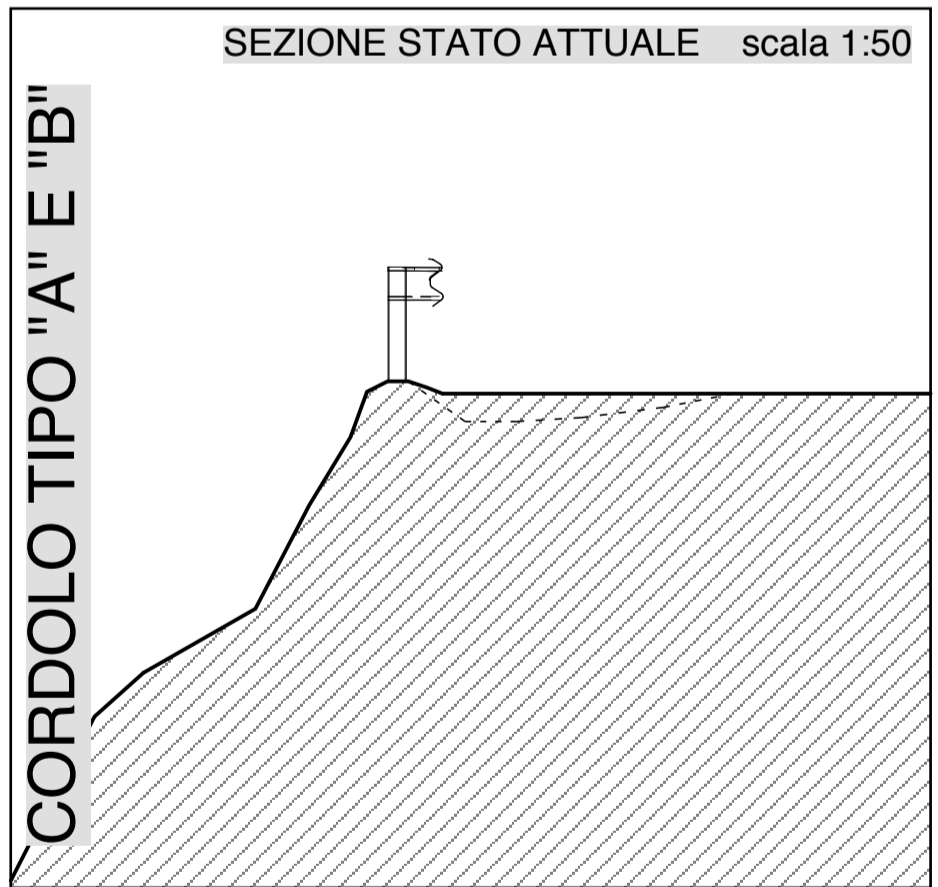
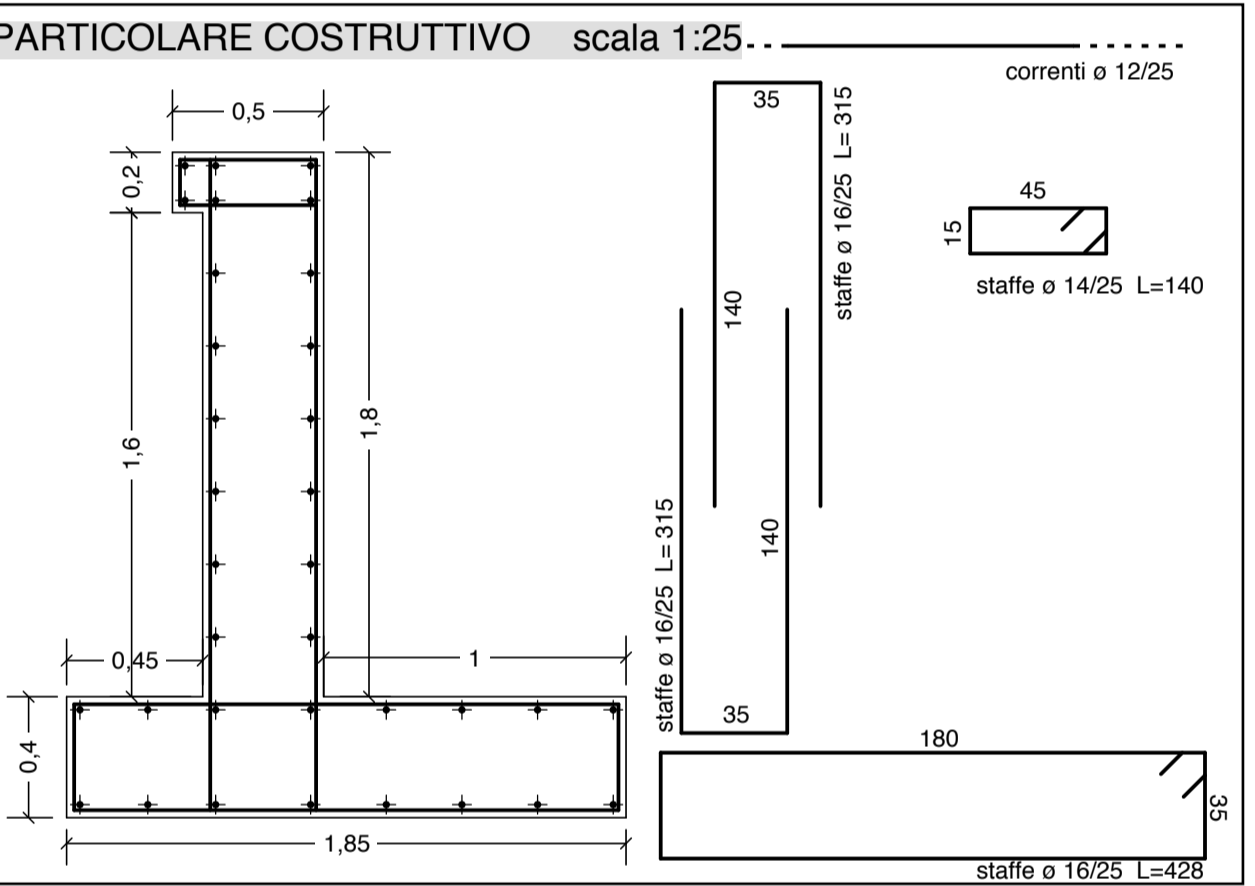
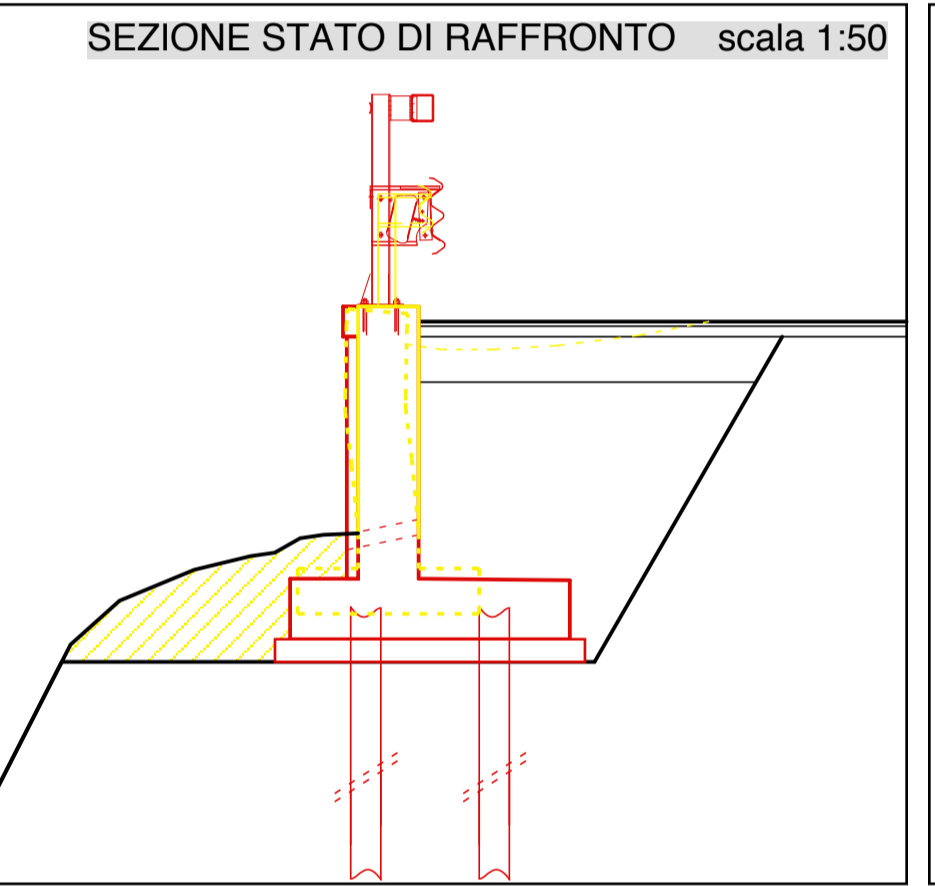
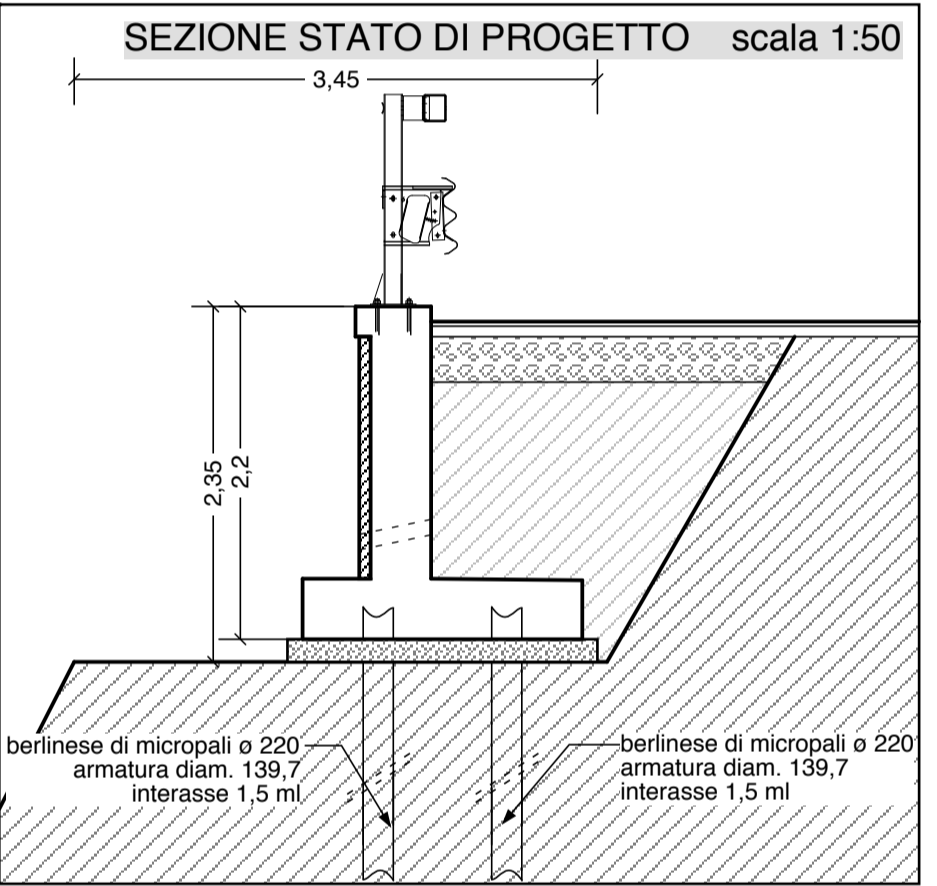
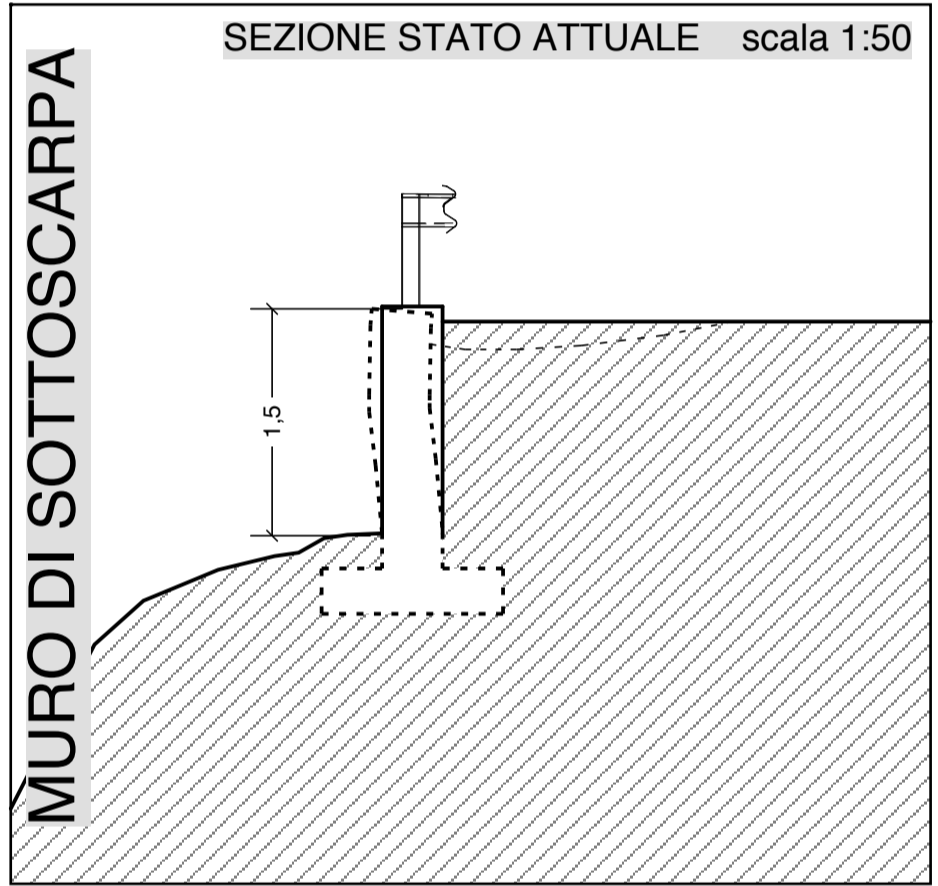
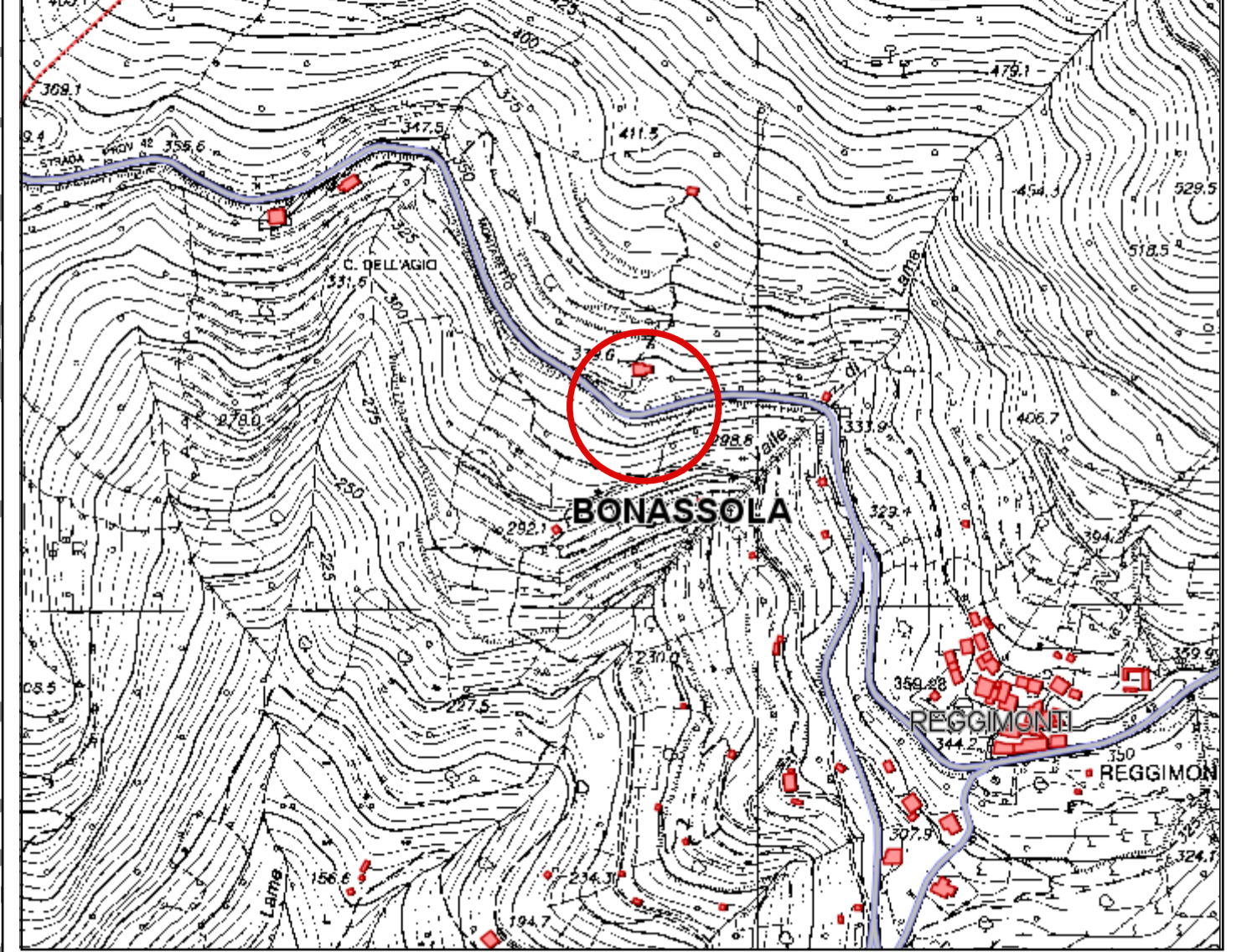

 PROVINCIA DELLA SPEZIA
 SETTORE 07 Difesa del Suolo
 Servizio Viabilità

IL RESPONSABILE DEL PROCEDIMENTO:
 Giotto Mancini
 Ingegnere

IL PROGETTISTA:
 Nicola BOLOGNA
 Geometra

 PROGETTO - Project
RIPRISTONO CEDIMENTO DI VALLE LUNGO LA S.P. N° 42 IN LOC. MONTARETTO
 COMMITTENTE - Customer LOCALITÀ - Site
 Comune di Bonassola
 DATI CATASTALI -
 TITOLO - Title
PROGETTO DEFINITIVO / ESECUTIVO
 Individuazione intervento - Planimetria - Sezioni Tipo

REV.	DESCRIZIONE - Description	DATA - Date	FASE - Phase	PROGETTO DEFINITIVO / ESECUTIVO	SCALA - Scale	REV. - Issue	ELABORATO DA - Document No.
A					VARIE	A	
B							
C							
D							

PRESENTATO / Presentato
 VERIFICATO / Checked
 APPROVATO / Approved
 DATA DISSEGNO / Date Drawn
 07.09.2012
 PROJECT No.
 Andrea/Cardella

Tav. unica